

This is a draft document, and has no official standing. It has not been submitted to the NMRA Technical Department or the NMRA Board of Directors for approval.

Written by J. Day, D. Harris, B. Jacobsen, and A. Shepherd

NMRA Technical Note	
NMRAnet[®] Physical Layer	
10/7/2010	Draft TN-9.x.1

1 Introduction

This Technical Note contains informative discussion and background for the corresponding S 9.x.1 Standard. This Technical Note is not normative in any way.

2 Annotations to the Standard

- 5 This section provides background information on corresponding sections of the S 9.x.1 Standard document. It's expected that the two documents will be read together.

2.1 Intended Use

- 10 The third paragraph, discussing networks that “(u)sers can expect to be able to form”, is based on CAN documentation, component-vendor specifications and application notes, and industrial experience with CAN. The intent is to set expectations that can be met essentially all of the time. The Standard does not restrict users from building, or attempting to build, networks that exceed these expectations. Often, NMRAnet layouts that somewhat exceed these expectations will be able to operate reliably.

- 15 The expected network sizes in section 2 of the Standard are based on UTP/RJ45 wiring of equipment that conforms to the Standard. Wiring and/or equipment that exceeds the Standard may result in being able to reliably build larger networks; alternate wiring or equipment may work well on smaller networks, but may not be able to reach the network sizes listed in that section.

- 20 The Standard discusses single CAN segments, and is silent on interconnecting multiple segments. For more discussion of options for interconnection, see the “Repeaters, Bridges and Gateways” section below.

2.2 References and Context

- 25 NMRA conformance testing is simplified when it can be done by referring to vendor documentation, rather than requiring specific tests of parameters. The Standard therefore refers to other existing standards, where possible, instead of repeating the information.

2.3 Physical Interconnection

The Standard envisions two basic kinds of nodes: A board with 2 connectors and a box with a pig-tail cable, e.g. a handheld throttle. At the same time, the Standard should not rule out other

30 implementations such as a board with two connectors and three pig-tails for attaching throttles, hence the somewhat complex wording in this section.

35 The Standard permits providing a terminal block for an alternate wiring of the CAN bus, for example to reduce the cost of small networks, so long as an RJ45 connector or connectors is provided for Standard-compliant wiring. For example, a manufacturer using a terminal block or blocks would provide an adapter board with the two RJ45s which will fit into the terminal block to make a Standard-conforming product. This adapter board may have provision for a termination resistors circuit. For mechanical simplicity, a pluggable terminal block could be used to connect the adapter board. As a by-product, if a pluggable RJ45 adapter were used, it would allow the module to be removed without any disturbance to the CAN segment and no need to link the two floating ends of the cable.

40 The signal names refer back to the signal definitions in the CAN specifications. UTP is unshielded cable, so the CAN_SHIELD conductor is being used as a second conductor for the CAN ground reference, CAN_GND.

The conductor assignments are based on industry practice for RJ45 connectors on CAN networks, c.f. Recommendation CiA 303 (2009) of the CAN in Automation e.V. group.

45 The assignments to particular wire colors are for information only. These are the wire colors that users will encounter in the two popular ways of wiring commercial cables. When building a product using commercial cable, using one of these two color assignments will reduce confusion, but most NMRAnet users will never need to refer to the wire colors in their cables.

50 The Standard does not require that all eight conductors be present in cables, but only the four that are minimally necessary for CAN communications. The reserved and power conductors are optional. This is because some low-cost "Ethernet" cables have only those required pairs present. Model railroaders who want to minimize cost, do not need distributed power, and are willing to forego future use of the reserved conductors can use these four-conductor "Ethernet" cables between nodes.

55 The discussion of connecting in parallel is to make sure that all 8 wires go through a board, whether it's got connectors, pig-tail cables or a combination of the two, so long as it's got more than one connection to other nodes.

The requirement to have all eight conductors present in nodes is so people can add power later, or an updated Standard can define the reserved conductors later, and still use them. The 1A requirement on interconnects is to make sure they're at least as robust as the connectors and cable.

60 For information on sizing circuit board traces to carry the required interconnection current, please see "IPC-2152 — Standard for Determining Current-carrying Capacity in Printed Board Design, 2009."

All 8 wires don't have to go through the board if there's only one connection, e.g. a throttle with a single jack or pig-tail cable with plug. In that case, only two pairs are required.

65 If a conforming device is providing power and has e.g. two jacks, the device can either connect them together and provide a max of 0.5A to both combined, or separately power them up to 0.5A each. This is the only case where a conductor doesn't have to pass through the board as a continuous electrical circuit. Note that this means that the device has to provide power, however; if providing power is an option, not always present, the device should connect conductor 8 across the board to ensure that downstream nodes aren't cut off from power when it's not provided by the device.

70 Note that the Standard permits, but does not require, connecting the CAN signal ground on conductors
 3 & 6 with the PWR_NEG power distribution ground on conductor 7. Power-supplying and power-
 consuming boards can connect PWR_NEG and the 3/6 grounds to simplify their internal structure.
 Designers should carefully consider noise immunity, the possibility of ground loops, and voltage offsets
 when doing this. A straight copper connection is within the letter of the requirement. An alternative to
 75 connecting them directly is a filtered connection, e.g. a 10 ohm resistor and a small RF choke or ferrite
 bead choke to isolate high frequency energy on the ground path.

Nodes that need a connection between conductor 7 and conductors 3 & 6 for proper operation are
 required to connect those conductors to avoid situations where the necessary connection is made on
 some other node, because that results in hard-to-diagnose bugs as the other node is connected and
 disconnected. It's also meant to avoid situations where the remote ground connection results in large
 80 ground currents and/or reduced noise margin.

The 100V requirement on the reserved conductors is there to make sure that when a use is defined for
 them later, it doesn't blow up existing installations. The goal is to have all existing installations be able
 to move to newly-defined uses without having to retrofit cables nor non-involved nodes.

To use the reserved conductors for experimental purposes, consider using jumpers (fixed or movable)
 85 for making connections to the conductors and/or splitting the reserved conductors between connectors
 so that the user can restore normal usage later, should some other use be defined for the reserved
 conductors.

One use of the reserved conductors would be to carry a DCC signal for synchronization or other
 purposes. This could be as an NMRA RP 9.1.2 signal or some other format. Note that the DCC signal
 90 has 1-bits that are 58 (nominal, min 55, max 61) microseconds long. The DCC signal has a 7th
 harmonic 8.28 (nominal, min 7.86, max 8.71) microseconds long, close to the CAN bit time of 8.00
 microseconds. A true square wave will have a 7th harmonic amplitude equal to $4/(7\pi)$ the amplitude of
 the square wave. For a DCC power signal this may be as large as 5 volts. The DCC track signal
 (NMRA S 9.1) is specified to have a slew rate at the origin of 2.5V/microsecond or larger. When
 95 putting DCC on the S 9.x.1 cable, the designer may want to consider ensuring balanced transmission,
 or reducing the amplitude or slew-rate of the DCC replica signal to reduce noise coupling into the CAN
 signal. (NMRA S 9.1 requires decoders to be largely immune to noise above 100kHz, which includes
 the CAN signal).

The 27V value in the no-damage requirement for the power connection comes from the S9.1 limitation
 100 on track voltage. In the unlikely case that a NMRAnet RJ45 connector is plugged into a telephone
 system, a ringing telephone line can provide as much as 100 volts.

Note that the ISO 11898-2 CAN specification for maximum rating of CAN drivers is -3.0, +16.0 or
 +32.0 volts. Some CAN transceiver parts have higher maximum input voltage ratings. Implementors
 should check the specifications of their selected CAN transceivers, and consider whether additional
 105 protection against over-voltage damage might be worthwhile if the maximum rating of the component
 is less than the maximum DCC track voltage.

2.4 Data Transport

A reduced slew rate is preferred to reduce the effect of stubs on the network (c.f. the calculation in
 section 4.8 of TI SLLA 270 <http://focus.ti.com/lit/an/slla270/slla270.pdf>) It's expected that model

railroad networks will eventually use stubs to e.g. connect to handheld devices, so it's important to build support for a reasonable number of stubs into the network specification from the start. Note that many off-the-shelf CAN transceiver parts have slew rates greater than 10V/microsecond by default. The recommended value for the slew rate is 4V/microsecond. The 3.5V/microsecond lower limit is specified to allow some manufacturing margin below the 4V/microsecond recommendation.

The Standard only requires that termination meet the CAN requirements, which are limited to the differential total resistance of the terminators. Industry uses some improved termination practices which are discussed in the “Bus Termination” section below.

The Standard is silent on the use of specific CAN frame formats or features.

120 **2.5 Supply of Power**

The power supply section is meant to define a 12V nominal system with wide margins on production and consumption of power over the UTP cable. The Standard is written to allow nodes to use this power in a range of ways, including having local power regulation ranging from simple analog regulators through more advanced supplies that increase current and/or voltage. 12V was chosen to reduce heat loads when using the simplest regulators. The current limit was required by use of one conductor in UTP wiring.

Power can be injected into the cable by simple “mid-span injector” devices, essentially just two RJ45 connectors and a 2.1mm jack for a wall-wart. It is not required that power comes from a full node implementation.

130 The power provisions are for low-power uses that can be conveniently handled over short lengths of cable. Boards are welcome to have other connectors for power. These other connectors can be anything not otherwise forbidden by some other standard, including terminal blocks, 2.1mm jacks, Anderson PowerPole connectors, or whatever else is considered useful for the specific market.

135 The wiring system is likely to result in power-supplying nodes being connected to each other. This is covered by the “shall withstand” voltage requirement: power supply boards must be able to be connected to each other, even if their output voltages are not exactly the same. One way to implement this is an isolating diode on the PWR_POS output. The closer the supply outputs are to the 12V nominal value, the better this will work.

2.6 Consumption of Power

140 For their thermal calculations, node designers should assume that power is supplied at 15V.

For their power calculations, node designers should assume that power is supplied at 7.5V.

3 Design Issues

This section contains discussion of issues that a designer may wish to consider when designing an NMRAnet product. Nothing in this section is normative.

145 **3.1 Bus Termination**

The CAN specification (ISO11898-2 section 7.1 and section 7.5.2) specifies the use of a bus termination resistor at each end of the bus of 120 (nominal; minimum 100, maximum 130) ohms and

rated for 220mW or more. Several alternate termination schemes have been proposed in the literature, and these alternatives are discussed below.

150 3.1.1 Termination Circuits

3.1.1.1 *Passive single resistor*

A single 120±10 ohm resistor of ¼ watt or more capacity can be connected between CAN-H and CAN-L. This approach has the advantage of simplicity.

3.1.1.2 *Passive split resistors bypassed to ground*

155 This consists of the CAN-L and CAN-H lines being connected by two 60 ohm resistors in series, with their common connected via a capacitor to ground. This provides a bypass to ground for common mode noise. The tolerance on the individual resistor values is significantly tighter than on their total resistance. Several references recommend 1% tolerance resistors to reduce coupling of the differential CAN signal into common mode noise (<http://focus.ti.com/lit/an/slla270/slla270.pdf>)
 160 (<http://focus.ti.com.cn/cn/lit/an/sloa101a/sloa101a.pdf>). Selecting matched pairs of resistors with looser nominal tolerance might be another solution.

3.1.1.3 *Biased split termination*

As in (3.1.1.2), but the common of the resistors is also tied to a fixed voltage. This can be to nominal 2.5V via a voltage divider (<http://ww1.microchip.com/downloads/en/AppNotes/00228a.pdf>), or by
 165 using a voltage reference (<http://focus.ti.com.cn/cn/lit/an/sloa101a/sloa101a.pdf>)
 (http://www.nxp.com/documents/application_note/AN10211.pdf). If there is a significant offset of ground between two nodes, then this offset will be transmitted to the CAN lines with consequent degradation of common-mode rejection.

3.1.1.4 *Active termination*

170 This termination is accomplished by using active elements, such as transistors or op-amps, to actively drive the bus to its proper state. Because of the recessive component of the ISO 11898-2 CAN signal, this form of termination is not appropriate.

3.1.1.5 *Distributed termination*

175 This technique requires a fixed number of custom-impedance nodes, and is therefore not suitable for model railroad applications that are based on user-specific ad-hoc networks made from standard components.

3.1.2 Terminator Placement

Termination can be supplied as an on-board option, or as a terminator housed within an RJ45 plug, or as a separate terminator device, depending on the preferences of the manufacturer and users.

180 Using plug-resident terminators would seem to provide the maximum flexibility, but it may be difficult to build a split terminator into a RJ45 plug.

185 If on-board terminators are provided, the Standard requires it be possible to enable or disable them depending on where the node is installed on the CAN segment. Termination should only occur at the two distant ends of the bus. Termination in the middle of a significant-length CAN bus is very disruptive because it causes reflections. The one downside to on-board termination is that it makes it much easier to have multiple terminators (customers think more must be good, and mistakenly turn them all on). It's required that nodes be shipped with on-board terminators disabled to reduce the chance that a termination load will be attached in the middle of the segment. Note that ISO11898-2 states "The locating of the termination within a CAN node should be avoided because the bus lines lose termination if this node is disconnected from the bus line." (Section 5.2.1) and "It is not recommended to integrate the termination into a CAN node." (Section 7.1)

190 Manufacturers may want to provide a special termination node to provide some indication of bus health as well as providing termination. Industrial diagnostic equipment provides some examples of what can be done. (http://www.microchip.com/stellent/idcplg?IdcService=SS_GET_PAGE&nodeId=1406&dDocName=en546534) (http://www.ixxat.com/cancheck_en.html?markierung=cancheck) (http://www.ixxat.com/can_bus_tester_cbt_en.html) (http://www.can-cia.org/pg/can/categories/generic_tool/physical/none/none/index.html)

3.2 EMC Management

200 CAN is a robust signaling method developed for use in the difficult environment of automobiles. Issues of EMC, noise reduction, etc have been discussed in numerous vendor application notes including, but not limited to:

http://www.nxp.com/documents/application_note/AN10211.pdf

<http://focus.ti.com/lit/an/slla270/slla270.pdf>

205 See also the "References" section below.

3.2.1 Chokes

210 A series choke or transformer can improve the noise immunity of a CAN transceiver. The Standard permits the use of one, but doesn't require it. The advantages and disadvantages of including one are discussed in the NXP (Philips) and Texas Instruments application notes referenced above. Typical parts are the TDK ZJYS81RS-2PL51(T)-G01 and the ZJYS51-2PT.

3.3 Sample Schematic

The following informative schematic is a sample of various possible design choices, and not normative in any way.

Independently
Powered
Node

Board-based
Termination

Bus-power
Supplying
Node

Bus-power
Using
Node

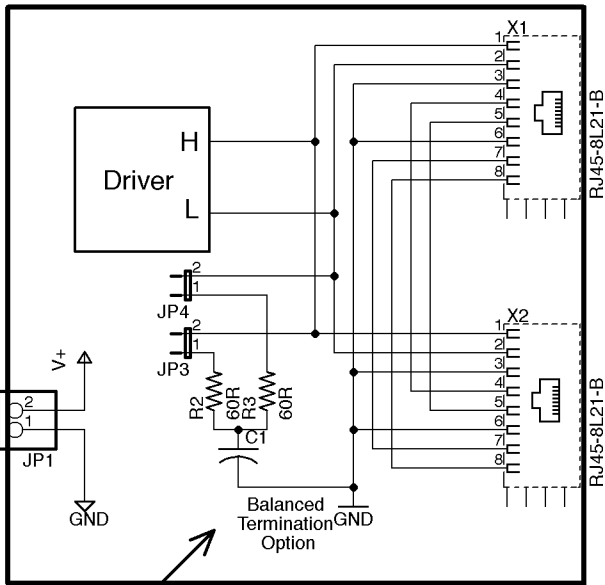

- CAN_H
- CAN_L
- CAN_GND
- reserved
- reserved
- CAN_SHIELD
- PWR_NEG
- PWR_POS

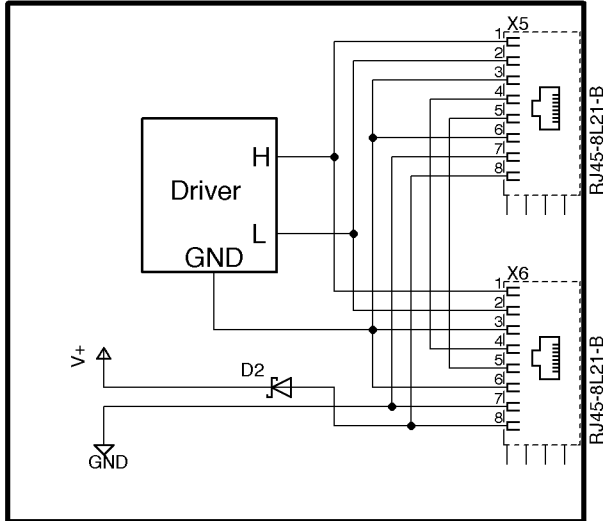
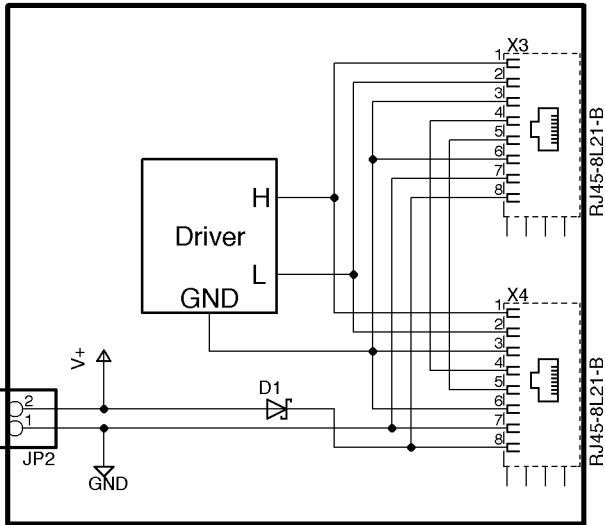

Connector-based
Termination

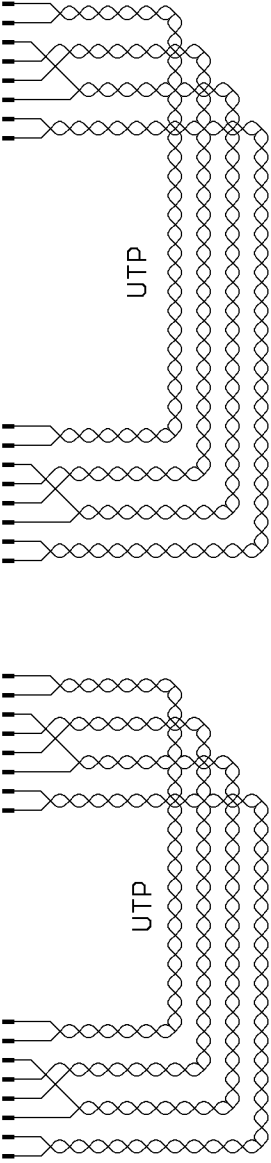

215 4 Repeaters, Bridges and Gateways

A CAN segment is a set of directly-connected cables that is shared by multiple nodes with directly-connected transceivers. Any node on the segment can communicate with any other node. A CAN segment has limited length, number of nodes and stub connections due to timing and electrical properties of the cables and transceivers.

220 Repeaters, bridges and gateways are different methods of connecting two or more CAN segments so that a node on one segment can communicate with nodes on any connected segment. This section provides some background information on these three alternatives. Note
225 that the terminology is somewhat flexible, and not all manufacturers will refer to their products in the same way.

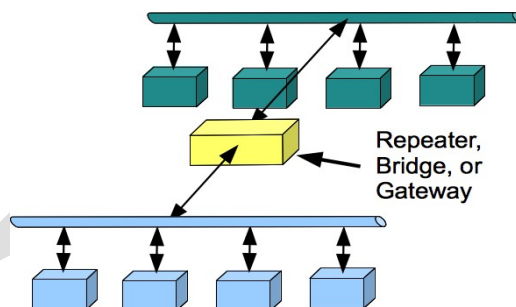

In each section, URLs are provided for a few example devices. Inclusion of a device in this section is informational, and does not imply a recommendation, positive or negative, for the device. No
230 inferences should be drawn from a device being or not being included in this section.

4.1 Repeaters

The number of nodes connected to a short CAN segment may be limited by the electrical drive characteristics of the transceivers for the CAN signal, without reaching the timing limitations of the CAN protocol. In this case, a repeater may be used to connect a second segment containing more
235 nodes. The repeater effectively boosts the electrical signals moving from one segment to the other, so that the nodes on one side appear as only a single electrical load on the other.

Doing this takes a small amount of time, so use of repeaters reduces the total possible end-to-end length of the combined CAN segments, typically reducing it by around 30 m / 100 ft per repeater. Under certain circumstances, they can be used to add long stubs to a CAN network; doing this successfully
240 requires detailed understanding of CAN characteristics.

Repeaters are sometimes referred to as “working at the bit level”. The CAN transmission is delayed by less than a bit time, and the CAN arbitration process still works between nodes on the two segments.

<http://www.softing.com/home/en/industrial-automation/products/can-bus/more-can-bus/high-speed/iso-11898-2-repeater.php>

245 http://www.ixxat.com/introduction-repeater_en.html

<http://www.esd-electronics-usa.com/shared/datasheets/repeat-e.pdf>

http://www.ixxat.com/can_cr200_en.html

4.2 Bridges

A bridge looks like an independent CAN node on each of two or more CAN segments, receiving
250 frames on a segment and sending them independently on the others. As such, it allows connection of two or more full size, full node-count CAN segments.

Bridges are sometimes referred to as “working at the frame level”. The CAN transmission is delayed by much more than a bit time, usually a frame time or longer.

255 The CAN arbitration process takes place on each segment independently, and is not shared between the separate segments; frames will appear in different order on the various segments. The protocol(s) running on the CAN segments must be compatible with this reordering if it's to work with bridge(s).

260 Because bridges break the timing connection between the connected segments, they can also be used for remote connections via non-CAN cables, wireless, etc. In this case, a bridge device is usually used at each end of the remote link, and the protocol between the two devices is specific to the CAN bridge function.

http://www.ixxat.com/introduction_bridges_en.html

<http://www.ieee-icnp.org/1996/papers/1996-21.pdf>

<http://doi.ieeecomputersociety.org/10.1109/ISPAN.1996.509033>

http://www.ixxat.com/can_bridge_en.html

265 http://www.wrcakron.com/devicenet/CAN_Bus_Applications.pdf

<http://www.matric.com/canbridge.html>

4.3 Gateways

270 Gateways connect a CAN segment to another communication technology, such as IP over wireless, Ethernet or some other. In the process, they may reformat or translate the CAN frames as needed. For example, a USB-CAN adapter may convert the CAN frame bytes into some form of human-readable text.

This reformatting may be independent of the CAN frame content information, or specific to some protocol that defines meaning for the CAN frames.

<http://www.phytec.com/products/can/pc-can-interfaces/CAN-Ethernet-Gateway.html>

275 <http://news.thomasnet.com/fullstory/Gateway-converts-from-CAN-into-Ethernet-529941>

<http://www.icpdas-usa.com/products.php?PID=3075>

5 References

This section provides references, and when possible URLs, that may be of use to NMRAnet implementors.

280 5.1 Standards

The S 9.x.1 Standard references ISO 11898-1 and ISO 11898-2 for CAN specifications. The ISO (<http://www.iso.org>) sells PDF and paper copies of these. Copies can generally be found in engineering libraries. (http://www.iso.org/iso/iso_catalogue/catalogue_tc/catalogue_detail.htm?csnumber=33422) (http://www.iso.org/iso/iso_catalogue/catalogue_tc/catalogue_detail.htm?csnumber=33423)

285 Note that ISO 11898-3, 11898-4 and 11898-5 specify different variants of the CAN standard that are not relevant to S 9.x.1 compliant implementations. The original 1995 Bosch CAN standard, which can be found online, is similar to ISO 11898-1 and -2, but not identical.

The S 9.x.1 Standard references TIA/EIA-568-B or the successor TIA/EIA- 568-C for unshielded twisted pair (UTP) cable, and TIA-968-A for RJ45 modular plugs and jacks. The TIA
 290 (<http://www.tiaonline.org>) sells PDF and paper copies of these. Copies can generally be found in engineering libraries.

5.2 Application Notes

A number of component manufacturers have written application notes that may be useful to NMRAnet developers. A list is provided here for reference, but note that none of these are normative; for specific
 295 values, etc, please refer to the standards listed above.

5.2.1 Anixter

“ANSI/TIA/EIA-568-B Standards Reference Guide”
 ([http://www.anixter.com/AXECOM/AXEDocLib.nsf/\(UnID\)/8F2E0839A6190F4986257309005757CC/\\$file/ANSI-TIA-EIA-568-B.pdf](http://www.anixter.com/AXECOM/AXEDocLib.nsf/(UnID)/8F2E0839A6190F4986257309005757CC/$file/ANSI-TIA-EIA-568-B.pdf))

300 5.2.2 Mohawk.com

“ANSI/TIA/EIA-568-B (B.1, B.2 and B.3) Commercial Building Telecommunications Cabling Standard” (<http://www.mohawk-cable.com/support/ansi-tia-eia-568-b.html>)

5.2.3 Microchip Corp

AN713 “Controller Area Network (CAN) Basics”
 305 (<http://ww1.microchip.com/downloads/en/AppNotes/00713a.pdf>)

AN228 “A CAN Physical Layer Discussion”
 (<http://ww1.microchip.com/downloads/en/AppNotes/00228a.pdf>)

AN853 “PIC18XXX8 CAN Driver with Prioritized Transmit Buffer”
 (<http://ww1.microchip.com/downloads/en/AppNotes/00853a.pdf>)

310 5.2.4 Philips

AN96116 “PCA82C250 / 251 CAN Transceiver”
 (http://www.nxp.com/documents/application_note/AN96116.pdf)

AN10211 “TJA1040 high speed CAN transceiver”
 (http://www.nxp.com/documents/application_note/AN10211.pdf)

315 5.2.5 Texas Instruments

Analog Applications Journal, August 1999, TI SLYT197 “TIA/EIA-568A Category 5 cables in low-voltage differential signaling (LVDS)” (<http://focus.ti.com/lit/an/slyt197/slyt197.pdf>)

Application Report SLOA101A “Introduction to the Controller Area Network (CAN)”
 (<http://focus.ti.com.cn/cn/lit/an/sloa101a/sloa101a.pdf>)

320 Application Report SLLA270 “Controller Area Network Physical Layer Requirements”
(<http://focus.ti.com/lit/an/slla270/slla270.pdf>)

Application Report SLLA298B “Isolated CAN Reference Design”
(<http://focus.ti.com/lit/an/slla298b/slla298b.pdf>)

325 Application Report SLOU262 “Isolated CAN Transceiver EVM”
(<http://focus.tij.co.jp/jp/lit/ug/slou262/slou262.pdf>)

Analog Applications Journal, 3Q 2006, TI SLYT249 “Improved CAN network security with TI’s SN65HVD1050 transceiver” (<http://focus.ti.com/lit/an/slyt249/slyt249.pdf>)

5.3 Component data sheets

330 This section lists component data sheets that may be of value to the NMRAnet implementor. Inclusion of a component data sheet in this section is informational, and does not imply a recommendation, positive or negative, for the component or data sheet. No inferences should be drawn from a component data sheet being or not being included in this section.

5.3.1 Microchip

335 MCP 2551 High-Speed CAN Transceiver
(<http://ww1.microchip.com/downloads/en/DeviceDoc/21667f.pdf>)

MCP2515 Stand-Alone CAN Controller With SPI Interface
(<http://ww1.microchip.com/downloads/en/DeviceDoc/21801e.pdf>)

5.3.2 NXP Electronics (Philips)

PCA82C250 CAN controller interface (http://www.nxp.com/documents/data_sheet/PCA82C250.pdf)

340 5.3.3 STMicroelectronics

L9615 transceiver (<http://www.st.com/stonline/products/literature/ds/5637.pdf>)

5.3.4 Texas Instruments

ISO1050 Isolated CAN Transceiver (<http://focus.ti.com/lit/ds/symlink/iso1050.pdf>)

345 SN55HVD251, SN65HVD251 Industrial CAN Transceiver
(<http://focus.ti.com/lit/ds/symlink/sn55hvd251.pdf>)

SN65HVD1050 EMC Optimized CAN Transceiver
(<http://focus.ti.com/lit/ds/symlink/sn65hvd1050.pdf>)

5.4 Tools

350 This section lists tools and diagnostic equipment that may be of value to the NMRAnet implementor. Inclusion of an item in this section is informational, and does not imply a recommendation, positive or negative, for the item. No inferences should be drawn from an item being or not being included in this section.

5.4.1 Microchip

355 CAN BUS Analyzer Tool “simple to use low cost CAN bus monitor”
(http://www.microchip.com/stellent/idcplg?IdcService=SS_GET_PAGE&nodeId=1406&dDocName=en546534)

5.4.2 IXAAT

CANcheck “Installation tester for CAN networks” (http://www.ixxat.com/cancheck_en.html?markierung=cancheck)

360 CAN Bus Tester “Diagnostic tool for long-term monitoring of CAN bus systems”
(http://www.ixxat.com/can_bus_tester_cbt_en.html)

DRAFT

Table of Contents

1 Introduction.....	1
2 Annotations to the Standard.....	1
2.1 Intended Use.....	1
2.2 References and Context.....	1
2.3 Physical Interconnection.....	1
2.4 Data Transport.....	3
2.5 Supply of Power.....	4
2.6 Consumption of Power.....	4
3 Design Issues.....	4
3.1 Bus Termination.....	4
3.1.1 Termination Circuits.....	5
3.1.1.1 Passive single resistor.....	5
3.1.1.2 Passive split resistors bypassed to ground.....	5
3.1.1.3 Biased split termination.....	5
3.1.1.4 Active termination.....	5
3.1.1.5 Distributed termination.....	5
3.1.2 Terminator Placement.....	5
3.2 EMC Management.....	6
3.2.1 Chokes.....	6
3.3 Sample Schematic.....	6
4 Repeaters, Bridges and Gateways.....	8
4.1 Repeaters.....	8
4.2 Bridges.....	8
4.3 Gateways.....	9
5 References.....	9
5.1 Standards.....	9

5.2 Application Notes..... 10

 5.2.1 Anixter..... 10

 5.2.2 Mohawk.com..... 10

 5.2.3 Microchip Corp..... 10

 5.2.4 Philips..... 10

 5.2.5 Texas Instruments..... 10

5.3 Component data sheets..... 11

 5.3.1 Microchip..... 11

 5.3.2 NXP Electronics (Philips)..... 11

 5.3.3 STMicroelectronics..... 11

 5.3.4 Texas Instruments..... 11

5.4 Tools..... 11

 5.4.1 Microchip 12

 5.4.2 IXAAT..... 12

DRAFT